

MONITOR PRODUCTS, INC.
15400 Flight Path Dr
Brooksville, FL 34604
Tel: 800-334-4591
Sales: ext 201
Technical Assistance: ext 209
Fax: 352-544-0870



3.0L ON-ENGINE
FRESHWATER COOLING
KIT SPECIFICATIONS

MFH-5344

MFH-5344 3.0L ON-ENGINE FRESHWATER COOLING KIT

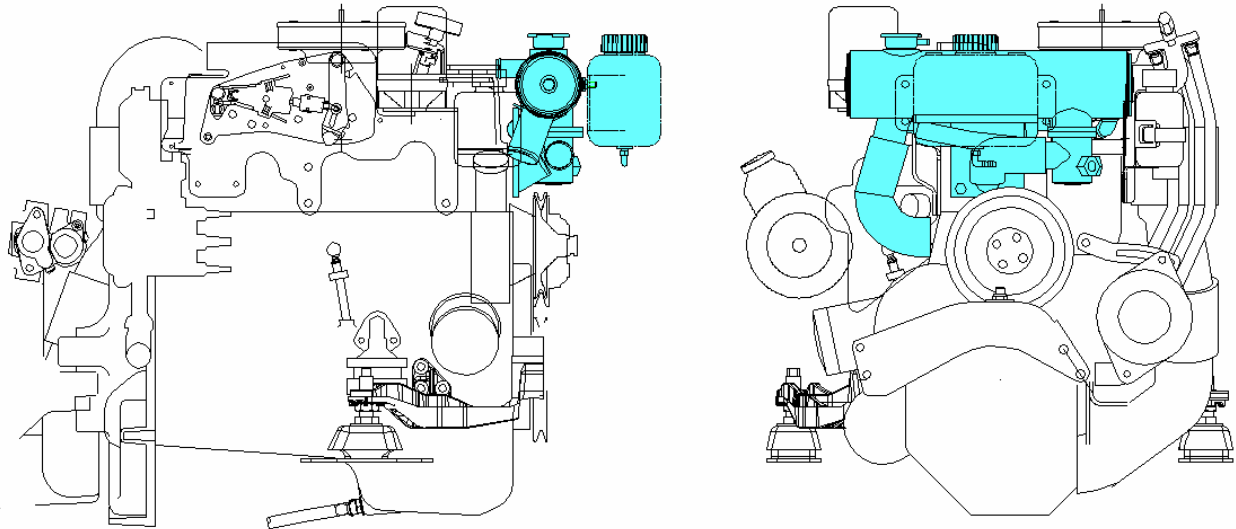

CONVERSION KIT FITS:

This conversion kit fits 4-cylinder 3.0L MerCruiser engines from 1997 to 2005 (S/N 0L010042 to 0M680000) and 1996-1997 MerCruiser engines (S/N 0F604000 to 0K999999). Kit will also fit on 3.0LX engines built from 1990 to 1995. Kit will NOT work with manifolds without flat end covers. See space requirements to confirm that it will fit within the engine compartment.

COOLING SYSTEM TYPE:

On-engine mounted.

Block only. (The engine block protected by freshwater system; the exhaust manifold and exhaust elbow remain on raw water system.)

CONVERSION KIT:

Kit includes heat exchanger, heavy-duty translucent plastic expansion tank plus all other components necessary to complete conversion. Some components from engine are reused. Heat Exchanger and Brackets are finished in black. Hose clamps are all stainless steel.

HEAT EXCHANGER:

Heat exchanger is shell and tube type with special high capacity design. All copper alloy construction made to the highest industry standards. Includes dual demountable end covers for easy clean out.

MONITOR PRODUCTS, INC.
15400 Flight Path Dr
Brooksville, FL 34604
Tel: 800-334-4591
Sales: ext 201
Technical Assistance: ext 209
Fax: 352-544-0870



3.0L ON-ENGINE
FRESHWATER COOLING
KIT SPECIFICATIONS

MFH-5344

SPACE REQUIREMENT:

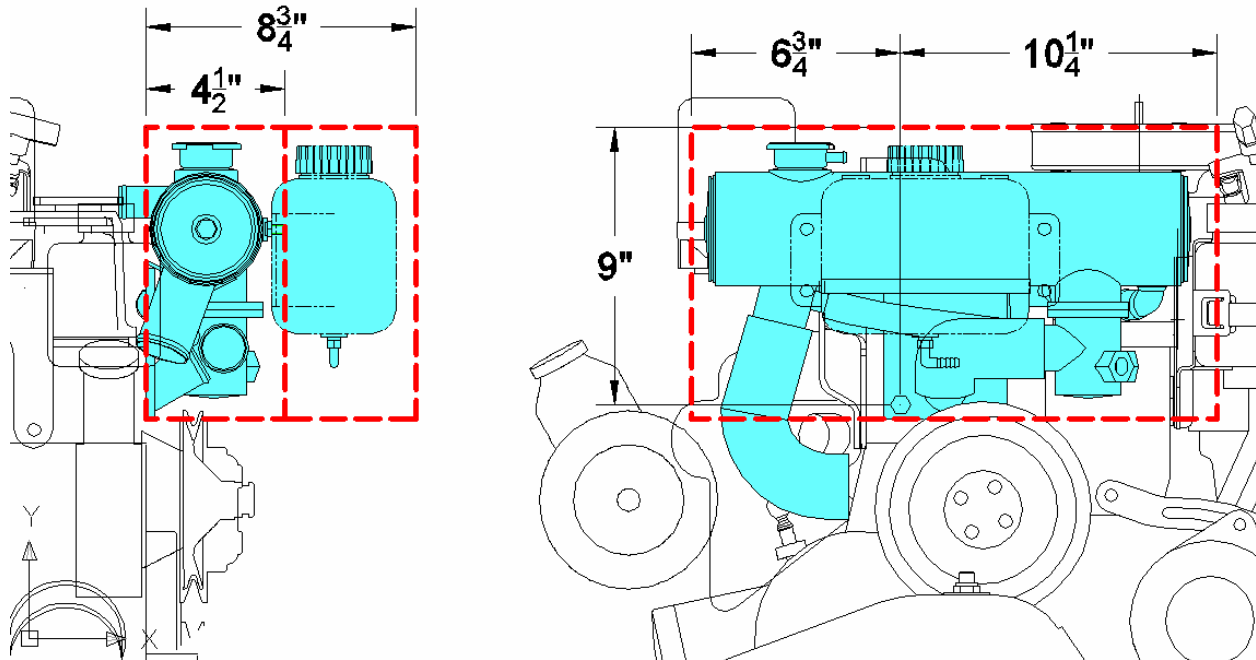

Before purchasing this system, make sure there is enough room in the engine compartment to accommodate the heat exchanger, expansion tank, and necessary components.

Heat exchanger is 3.69" diameter x 17" overall length. Heat exchanger is mounted on the front of the engine in the location of the current thermostat housing. The mounting bracket is included with the kit. When installed the heat exchanger extends 4 1/2" in front of the engine block (see above).

Expansion tank can be mounted on the front of the heat exchanger with supplied hardware or remote mounted at the same level as the filler neck. Required space is 4" x 6" x 8 1/2". The expansion tank must be mounted as close to the engine as possible. The mounting locations should not hinder the opening or closing of the hatch. Do not drill into fuel tanks, water tanks, or any other critical areas. Do not contact any belts or fuel lines.

MONITOR PRODUCTS, INC.
15400 Flight Path Dr
Brooksville, FL 34604
Tel: 800-334-4591
Sales: ext 201
Technical Assistance: ext 209
Fax: 352-544-0870



3.0L ON-ENGINE
FRESHWATER COOLING
KIT SPECIFICATIONS

MFH-5344

COOLING SYSTEM CAPACITY:

The heat exchanger will maintain coolant temperatures in the 160-170°F range using 160°F thermostat included in kit. The system has a cooling capacity safety margin higher than industry standards.

HEATER SYSTEM HOOKUP:

Heaters such as galley water heaters and cabin heaters are not recommended on four-cylinder engines because they may over-cool the engine.

INSTALLATION TIME:

Average installation time is approximately three hours, assuming new engine and normal accessibility. Allow additional time for filling and testing. Installation skills are typical of most do-it-yourself boat owners. Complete illustrated installation instructions are included in kit.

WARRANTY:

Two-year warranty on complete kit. We will not be responsible for labor charges or any indirect or consequential costs or damages.

MONEY BACK GUARANTEE:

Full refund if kit is returned within 30 days in original box and in undamaged condition.

PRICE:

Trade and volume discounts available. Buy through your dealer or direct using Visa, MasterCard, Amex, UPS COD, or Money order.